

Automated Blood Sampling and Glucose Sensing in Critical Care Settings

Kislaya Kunjan, M.S., M.B.A., and Frank P. Lloyd, Jr., M.D.

Abstract

Background:

Tight glycemic control (TGC) studies in intensive care units (ICU) have shown substantial improvements in clinical outcomes. However, implementation of TGC in ICU practice is partly constrained by the lack of automated continuous blood glucose monitoring systems that can facilitate clinically accurate feedback of glycemic data. The aim of this work is to develop a portable automated blood sampling system for integration with a glucose sensor for use in critical care settings.

Methods:

Clinical prototypes for glucose sensing in blood were developed based on two distinct technologies: mid-infrared laser absorption spectroscopy and electrochemistry. Concurrently, an automated peripheral venous blood sampling system was developed for integration with the glucose sensing system.

Results:

The glucose sensing prototypes were validated clinically with various biological samples in a continuous mode. A customized micropump was employed in conjunction with a novel peripheral venous catheter system to automatically sample blood from the subject's forearm. Microvolumes of blood were sampled in continuous and intermittent modes at clinically relevant user-defined frequencies. The clinical feasibility of blood sampling, along with continuous glucose sensing, was demonstrated.

Conclusion:

Cascade's automated peripheral venous blood sampling system, in combination with a flow-through glucose sensor system, offers several advantages over current state-of-the-art systems. This includes the potential for significantly improved workflow in the ICU, minimal discomfort to the patient, and accurate glucose measurement in whole blood, thus helping achieve tight glycemic control.

J Diabetes Sci Technol 2008;2(2):194-200

Author Affiliation: Cascade Metrix, Inc., Indianapolis, Indiana

Abbreviations: (FAD) flavin adenine dinucleotide, (FTIR) Fourier transform infrared, (GOx) glucose oxidase, (ICU) intensive care unit, (ISF) interstitial fluid, (QCL) quantum cascade lasers, (TGC) tight glycemic control

Keywords: automated blood sampling, continuous glucose monitoring, mid-infrared quantum cascade laser spectroscopy, tight glycemic control

Corresponding Author: Kislaya Kunjan, M.S., M.B.A., Cascade Metrix, Inc., 1633 N. Capitol Ave, Indianapolis, IN 46202; email address kkunjan@cascademetrix.com

Introduction

There is now a widespread consensus in the medical community that tight control of blood glucose levels [also known as tight glycemic control (TGC)] leads to notable improvements in the clinical outcome of patients in critical care.¹ Medical evidence points to the substantial adverse effects of hyperglycemia (as an independent risk factor) on morbidity, mortality, and hospital length of stay.² Although a serious concern, the incidence of significant hypoglycemia as a complication of treatment has been under 2%.³ At the core of TGC by intensive insulin therapy is frequent and accurate glucose monitoring. More recently, evidence supports the need for an automated continuous “vascular” blood glucose monitor for use in critical care.⁴ The purpose of this article is to discuss the development of Cascade’s automated blood sampling system and its integration with a glucose sensing system for use in critical care settings.

Problem Description

Current TGC protocols involve hourly or semihourly blood glucose measurements using point-of-care devices followed by appropriate insulin dosing. Sampling procedures involve either capillary blood (via finger sticks) or intermittent venous/arterial blood draws via an indwelling catheter. However, these protocols are time-consuming, labor-intensive, and prone to potential measurement errors. Near-continuous blood glucose monitoring is well recognized as a promising modality for enabling TGC in intensive care. Currently available continuous monitoring systems utilize subcutaneous implants for sensing glucose in the interstitial fluid (ISF). Although the correlation between blood glucose and ISF is well maintained during normal physiology, patients in the intensive care unit (ICU) do not have a predictable pattern, and devices that rely on interstitial measurements have found limited use in critical care settings.^{5,6} Glucose measurements in the vasculature will minimize various sources of bias encountered in capillary or interstitial fluid-based glucose monitors.

Blood sampling and glucose sensing make up the two aspects of a “blood” glucose monitoring system. The article by Weiss and Lazar⁴ particularly elaborates on the importance of making glucose measurements in vascular-derived samples. Some of the desirable attributes of a blood sampling system for glucose measurements may include the following.

- Automation in blood sampling to minimize excessive labor and risk of contamination associated with repetitive sampling
- Functionality over at least 3 days with minimal risk of thrombophlebitis
- Customizable options for sampling intervals, lessening the need for caregiver intervention
- Minimization of the blood sample size per analytical measurement, thus obviating the need for volume replacement
- Convenient blood access, such as from a peripherally inserted venous catheter vis-à-vis arterial or centrally placed venous catheters
- Automated flow control capabilities for switching between blood and other fluids

Blood glucose monitoring systems have not yet been integrated with such a sampling technology for use in critical care, although STG22 (Nikisso, Japan) and the now discontinued Biostator (Miles Lab, IN) are few systems that offer(ed) some of these capabilities.

Methods

A brief description of Cascade’s blood sampling system that fulfills the aforementioned desirable features is now provided. This is then followed by a description of glucose sensing technologies also developed by the company for integration with its blood sampling system.

Blood Sampling

Cascade Metrix has developed a novel peripheral venous blood sampling technology platform. It consists of a highly miniaturized system capable of integrating with flow-through sensor technologies. A microbore catheter with special design features is inserted into a peripheral vein and secured in place. A programmable customized micropump communicates with this catheter assembly for blood withdrawal and transport to the flow-through sensor system. The total blood volume withdrawn by the system for analytical measurements is minimal, thus precluding the need for volume replacement. The unique design of the fluidic assembly prevents thrombus formation and is designed to minimize infection for up to 3 days. The system accommodates patient mobility and is much less invasive compared to sampling from the arterial line or central venous system. The operator

sets the flow rate and time intervals between drawing samples for a truly automated operation. The system also incorporates automated flow control capabilities for switching between different fluids, as may be necessary for rinsing or sensor calibration.

Glucose Sensing

Two technologies of blood glucose sensing have been evaluated for integration with the sampling system. The first is based on mid-infrared laser absorption spectroscopy and the second is based on the more prevalent electrochemical technology. Both methods involve integration of flow-through cells with the blood sampling system. The obvious point of difference is in the sensing methodology. The mid-infrared approach was the first approach pursued followed by the electrochemical method.

Results

Blood Sampling System

The miniature blood sampling system developed by Cascade was validated in a clinical setting. Following institutional review board approval at Clarian Hospital, Indiana, the peripheral venous blood sampling system was tested on multiple human samples. All the key features of the system, such as automation, thrombus resistance, fluidic control, and manipulation, were validated successfully. The prototypical system has also been integrated with various blood glucose sensors suitable for use in the ICU.

The remaining portion of this article describes the company's blood glucose sensing methods and its integration with the blood sampling system.

Mid-Infrared Glucose Sensing System

Because of its unique specificity for identifiable molecules of interest, mid-infrared spectroscopy is a well-researched technology for biological sensing. Infrared spectroscopy, in general, involves studying the absorption of electromagnetic radiation by molecules, often for quantitative analysis. A linear relationship exists between absorbance and concentration of an absorber of electromagnetic radiation. Assuming that the absorbance of a particular analyte is overlapped by absorbance from other constituents, the general form of the relationship is usually written as $A = \sum \epsilon_i C_i L$, where A is the absorbance, ϵ is the molar absorptivity, C is the concentration of the constituent, L is the optical path length, and the subscript "i" corresponds to the

specific constituent in the absorbing compound. The attenuation in intensity can be evaluated as a function of wavelength in order to extract information from the spectrum concerning the concentration of the analyte in the sample.

Fourier transform infrared (FTIR) spectrometric studies were initially performed in collaboration with a mid-infrared consortium at Purdue University, IN.⁷ This helped to ascertain the specific wavelengths of interest in the mid-infrared region for accurate glucose quantification. **Figure 1** shows absorption spectra (i.e., absorbance over different wavelengths) of glucose and commonly found spectral interferents in biological fluids such as urea, lactate, amino acids, and ascorbic acid. Note also the strongest mid-infrared absorption peak of glucose in this spectral region.

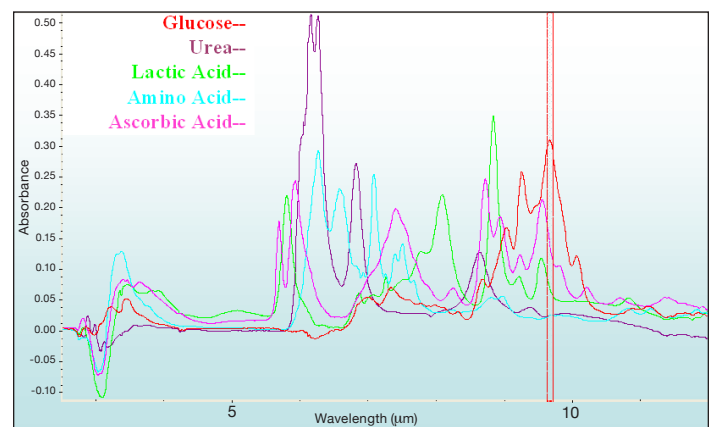

Figure 1. FTIR spectral studies of glucose and common spectral interferents.

Numerous research groups have described the feasibility of glucose measurements in whole blood using FTIR transmission spectroscopy^{8,9} and reflection spectroscopy.^{10,11} A few groups have even assessed quantum cascade lasers (QCL) as mid-infrared light sources for glucose measurement in biological samples. Lambrecht and co-workers¹² carried out aqueous glucose measurements as a step toward developing a mid-infrared, fiber-based continuous glucose monitoring system using a single wavelength quantum cascade laser, whereas Martin and colleagues¹³ used a cryogenically cooled system to carry out discretized glucose measurements in spiked samples of charcoal-adsorbed delipidated serum.

All absorption spectroscopic sensors feature a radiation source, a defined absorption path, and a detector. As a first step, an experimental miniature spectroscopic unit was developed based on an incandescent light

source and a pyroelectric detector. A seven subject oral glucose tolerance test study was carried out using static blood samples that were ultrafiltered to mimic ISF fluid, and data were analyzed on a Clarke error grid. Although the results were promising (**Figure 2**), the experimental unit had several technical shortcomings. The system sensitivity was low and ISF sampling on a continuous basis proved to be challenging. Additionally, as discussed earlier, ISF-based measurements are suboptimal for enabling tight glycemic control in the critical care environment.

It is well known in spectrometry that thermal light sources behave like a black body source, requiring the optical path length to be in the low micrometer range. The consequence of a short optical path length is a limitation in sensitivity. To achieve higher sensitivity, a higher intensity light source is required.¹⁴ The recent availability of mid-infrared QCL technology has provided this capability. Other advantages of QCLs include small size, possibility for hybrid integration, and mechanical robustness.

In light of what was just discussed, Cascade carried out several modifications of the sensor hardware to improve sensitivity and to generate a capability for making blood-based measurements suitable for the ICU. The broadband thermal light source used in the initial experimental unit was replaced with a monochromatic mid-infrared quantum cascade laser, allowing for a multifold increase in sensitivity. A thermoelectrically cooled mercury–cadmium–telluride photoconductive detector was used in place of the pyroelectric detector, and the fluidic module was redesigned to handle complex biological fluids. **Figure 3** shows a schematic of the optical and electronic setup based on the mid-infrared quantum cascade laser.

Various proof-of-principle studies were performed on the aforementioned embodiment of the QCL-based sensor prototype. The idea of these studies was to simulate real-life conditions by monitoring changes in the glucose-specific signal while continuously pumping randomly selected glucose-doped samples through the transmission flow cell. A clinically relevant dynamic range of glucose concentrations was selected to monitor the real-time sensor response. The results described later show that the sensor prototype can accurately resolve clinically significant changes in glucose concentration with high sensitivity over the entire dynamic range. A two-point calibration model was used to accurately predict the glucose concentrations.

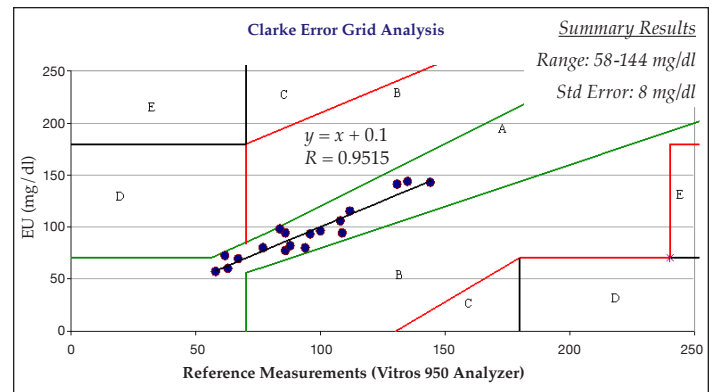

Figure 2. Clinical results with a thermal light source-based mid-infrared sensor system.

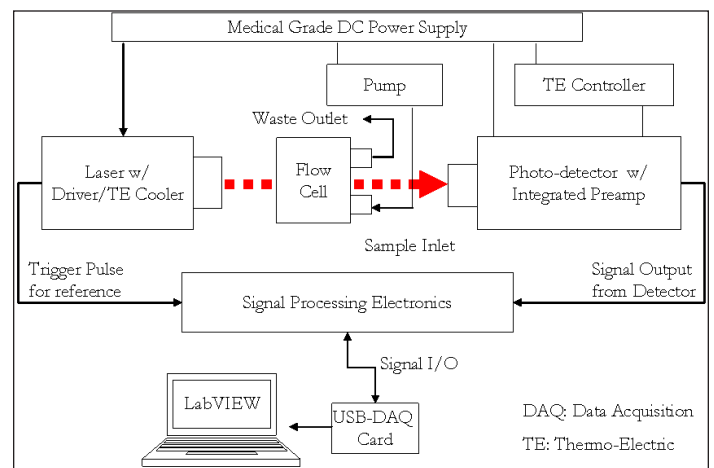

Figure 3. Schematic of the mid-infrared optoelectronic setup.

Human serum depleted of its glucose was chosen as the first biological sample for testing on the mid-infrared system. The base glucose concentration was negligible, and all higher concentrations were prepared by spiking with a glucose stock solution to evaluate sensor performance in both hypo- and hyperglycemic regions. Real-time sensor responses were recorded while sequentially introducing serum samples having different glucose concentrations.

For testing with whole blood, a healthy human subject's blood was drawn and the blood cells were allowed to metabolize the existing glucose to achieve a low blood glucose concentration of 70 mg/dl. Higher glucose concentrations were prepared by adding glucose in appropriate amounts. Each sample was sequentially pumped through the flow cell. The transmitted signal changes were observed in real time. **Figure 4** shows the real-time signal response for different concentrations (mg/dl) of glucose in serum (**top**) and whole blood (**bottom**).

The mid-infrared system showed high accuracy and sensitivity even in the hypoglycemic region (**Figure 4**). The real-time glucose detection in serum and whole blood with the mid-infrared system has set the stage for the next level of product development based on tunable quantum cascade lasers and expanded clinical validation studies with diabetic samples.

While the reagent-less approach of mid-infrared sensing has substantial merits, it is more likely to serve as next-generation technology. Cascade has therefore also evaluated the mature electrochemical sensor technology for integration with its blood sampling system.

Electrochemical Glucose Sensing

Electrochemical glucose sensors function by the production of a current when a potential is applied between a working and a reference electrode. The working electrode typically has an enzyme, glucose oxidase (GOx), on its surface, which catalyzes the oxidation of glucose in the biological sample. In order to work as a catalyst, GOx requires a cofactor, flavin adenine dinucleotide (FAD), which is a common component in biological oxidation–reduction (redox) reactions. The typical reactions in these electrochemical (amperometric) glucose sensors are as follows:

Glucose + GOx-FAD \rightarrow GOx-FADH₂ + gluconolactone

At biocatalyst: GOx-FADH₂ + O₂ \rightarrow GOx-FAD + H₂O₂

At electrode: H₂O₂ \rightarrow O₂ + 2H⁺ + 2e⁻

The current produced by this reaction is proportional to the glucose concentration in the sample. A straight line calibration curve is determined by measuring the signal level from two known concentrations. This two-point calibration adjusts for both the offset and the slope drift of the sensor system, thus enabling accurate glucose quantification.

Cascade constructed an immobilized glucose oxidase sensor with a multilayered polymeric coating suitable for blood glucose sensing. These sensor electrodes were integrated into the flow cell as shown in **Figure 5**.

The inlet and outlet fluidic ports were interfaced with the pumping mechanism. A potentiostat was used to maintain the potential of the working electrode at a constant level with respect to the reference electrode. Data acquisition and fluidic control were done using an input/output card and LabVIEW software (National Instruments, TX).

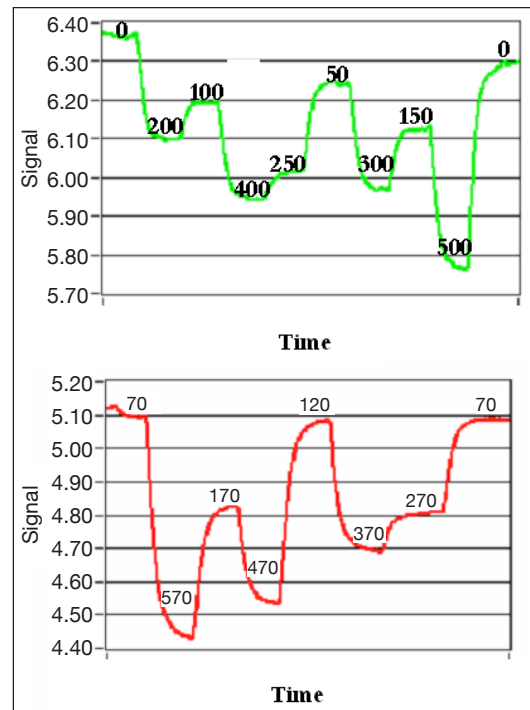

Figure 4. Real-time monitoring of glucose spiked in human serum (**top**) and whole blood (**bottom**).

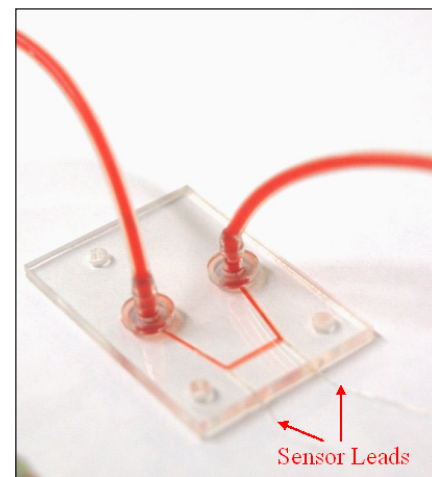

Figure 5. Microfluidic amperometric flow sensor.

Preliminary testing was done with a phosphate-buffered saline solution spiked with varying concentrations of glucose, which was pumped through the amperometric flow cell. The sensor output was recorded over the range of glucose concentrations with intermittent rinsing for baseline verification (**Figure 6**).

In yet another study, Cascade established the clinical feasibility of using “needle-type” glucose sensors in a unique combination with its blood sampling system.

Venous blood was drawn from a patient and was progressively spiked with glucose to get a range of concentrations from 90 to 400 mg/dl with average increments of approximately 5 mg/dl. After a simple calibration procedure, glucose determinations were recorded by the sensor system at a preset frequency. **Figure 7** shows glucose sensing system readouts for increasing concentrations of glucose in whole blood.

Discussion

All of these studies by Cascade have essentially established the use of multiple glucose sensing technologies in combination with an automated blood sampling system for near-continuous glucose measurements in critical care. This integrated system can communicate with insulin infusion algorithms, such as the Clarian GlucoStabilizer™, to enable tight glycemic control. Product optimization and clinical trial activities are currently underway in anticipation of regulatory filing.

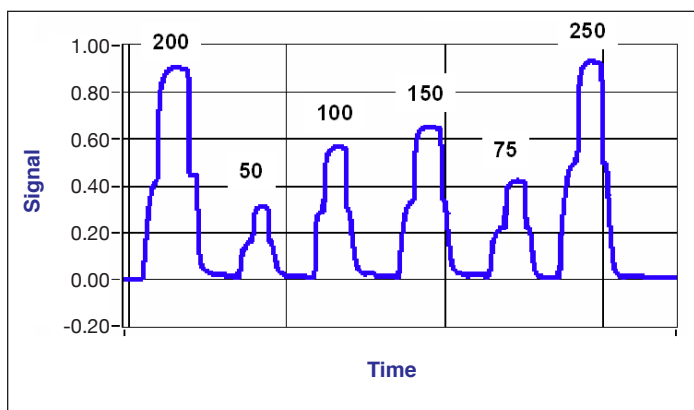

Figure 6. Amperometric flow sensor response with different glucose concentrations (mg/dl).

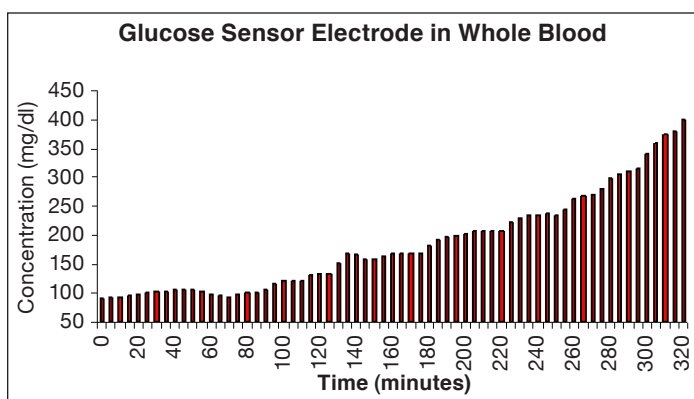

Figure 7. Automated blood glucose measurements using a needle-type glucose sensor.

Conclusion

An automated peripheral venous blood sampling system has been successfully built and tested. Product feasibility for a mid-infrared quantum cascade laser-based system was established. Furthermore, electrochemical systems have also been developed for integration with the blood sampling system. Analytes other than glucose, such as blood gases, electrolytes, and other metabolites, can also be measured using this approach in an automated fashion. The current nationwide pursuit of implementing tight glycemic control protocols in hospitals has necessitated near-continuous measurement of blood glucose. Cascade's automated blood sampling system coupled to a flow-through glucose sensor system is poised to fulfill this critical need.

References:

- Inzucchi SE, Sherwin RS. Inpatient glucose control: a new clinical mandate. *Am Diabetes Association Newsl.* 2006;13(2):1-3.
- Van den Berghe G, Wilmer A, Hermans G, Meersseman W, Wouters PJ, Milants I, Van Wijngaerden E, Bobbaers H, Bouillon R. Intensive insulin therapy in the medical ICU. *N Engl J Med.* 2006;354(5):449-61.
- Reed CC, Stewart RM, Sherman M, Myers JG, Corneille MG, Larson N, Gerhardt S, Beadle R, Gamboa C, Dent D, Cohn SM, Pruitt BA Jr. Intensive insulin protocol improves glucose control and is associated with a reduction in intensive care unit mortality. *J Am Coll Surg.* 2007;204(5):1048-54.
- Weiss R, Lazar I. The need for continuous blood glucose monitoring in the intensive care unit. *J Diabetes Sci Technol.* 2007;1(3):412-4.
- Wilson GS, Gifford R. Biosensors for real-time in vivo measurements. *Biosens Bioelectron.* 2005;20(12):2388-403.
- Gravesen P, Poulsen KR, Dirac H. Lab-on-a-chip technology for continuous glucose monitoring. *J Diabetes Sci Technol.* 2007;1(3):372-4.
- Kunjan K, Gore JP, Krishnan SS; Design and Development of a Mid-Infrared Glucose Sensor for Diabetics; MSME Thesis; Purdue University, West Lafayette, 2003.
- Kim YJ, Hahn S, Yoon G. Determination of glucose in whole blood samples by mid-infrared spectroscopy. *Appl Opt.* 2003;42(4):745-9.
- Vonach R, Buschmann J, Falkowski R, Schindler R, Lendl B, Kellner R. Application of mid-infrared transmission spectrometry to the direct determination of glucose in whole blood. *Appl Spectrosc.* 1998;52(6):820-2.
- Heise HM, Küpperb L, Butvinac LN. Attenuated total reflection mid-infrared spectroscopy for clinical chemistry applications using silver halide fibers. *Sens Actuators B.* 1998;51(1-3):84-91.
- Ward KJ, Haaland DM, Robinson MR, Eaton RP. Post-prandial blood glucose determination by quantitative mid-infrared spectroscopy. *Appl Spectrosc.* 1992;46(6):891-1076.
- Lambrecht A, Beyer T, Hebestreit K, Mischler R, Petrich W. Continuous glucose monitoring by means of fiber-based, mid-infrared laser spectroscopy. *Appl Spectrosc.* 2006;60:729-36.

13. Martin WB, Mirov S, Venugopalan R. Middle infrared quantum cascade laser optoelectronic absorption system for monitoring glucose in serum. *Appl Spectrosc.* 2005;59:881-4.
14. Edelmann A, Ruzicka C, Frank J, Lendl B, Schrenk W, Gornik E, Strasser E. Towards functional group-specific detection in high-performance liquid chromatography using mid-infrared quantum cascade lasers. *J Chromatogr A.* 2001;934(1-2):123-8.